



INTERNATIONAL
STANDARD

ISO
2010

Third edition
1994-04-01

**Countersunk slotted raised head screws
(common head style) — Product grade A**

Vis à métaux à tête fraisée bombée fendue — Grade A



Reference number
ISO 2010:1994(E)

Foreword

ISO (the International Organization for Standardization) is a worldwide federation of national standards bodies (ISO member bodies). The work of preparing International Standards is normally carried out through ISO technical committees. Each member body interested in a subject for which a technical committee has been established has the right to be represented on that committee. International organizations, governmental and non-governmental, in liaison with ISO, also take part in the work. ISO collaborates closely with the International Electrotechnical Commission (IEC) on all matters of electrotechnical standardization.

Draft International Standards adopted by the technical committees are circulated to the member bodies for voting. Publication as an International Standard requires approval by at least 75 % of the member bodies casting a vote.

International Standard ISO 2010 was prepared by Technical Committee ISO/TC 2, *Fasteners*.

This third edition cancels and replaces the second edition (ISO 2010:1983), which has been technically revised.

© ISO 1994

All rights reserved. Unless otherwise specified, no part of this publication may be reproduced or utilized in any form or by any means, electronic or mechanical, including photocopying and microfilm, without permission in writing from the publisher.

International Organization for Standardization
Case Postale 56 • CH-1211 Genève 20 • Switzerland

Printed in Switzerland

Countersunk slotted raised head screws (common head style) — Product grade A

1 Scope

This International Standard specifies the characteristics of countersunk slotted raised head screws of product grade A and with threads from M1,6 to M10 inclusive.

If, in special cases, specifications other than those listed in this International Standard are required, they should be selected from existing International Standards, for example ISO 261, ISO 888, ISO 898-1, ISO 965-2 and ISO 3506.

2 Normative references

The following standards contain provisions which, through reference in this text, constitute provisions of this International Standard. At the time of publication, the editions indicated were valid. All standards are subject to revision, and parties to agreements based on this International Standard are encouraged to investigate the possibility of applying the most recent editions of the standards indicated below. Members of IEC and ISO maintain registers of currently valid International Standards.

ISO 225:1983, *Fasteners — Bolts, screws, studs and nuts — Symbols and designations of dimensions.*

ISO 261:1973, *ISO general purpose metric screw threads — General plan.*

ISO 888:1976, *Bolts, screws and studs — Nominal lengths, and thread lengths for general purpose bolts.*

ISO 898-1:1988, *Mechanical properties of fasteners — Part 1: Bolts, screws and studs.*

ISO 965-2:1980, *ISO general purpose metric screw threads — Tolerances — Part 2: Limits of sizes for general purpose bolt and nut threads — Medium quality.*

ISO 3269:1988, *Fasteners — Acceptance inspection.*

ISO 3508:1979, *Corrosion-resistant stainless steel fasteners — Specifications.*

ISO 4042:1989, *Threaded components — Electroplated coatings.*

ISO 4759-1:1978, *Tolerances for fasteners — Part 1: Bolts, screws and nuts with thread diameters between 1,6 (inclusive) and 150 mm (inclusive) and product grades A, B and C.*

ISO 6157-1:1988, *Fasteners — Surface discontinuities — Part 1: Bolts, screws and studs for general requirements.*

ISO 7721:1983, *Countersunk head screws — Head configuration and gauging.*

ISO 8839:1986, *Mechanical properties of fasteners — Bolts, screws, studs and nuts made of non-ferrous metals.*

ISO 8992:1986, *Fasteners — General requirements for bolts, screws, studs and nuts.*

3 Dimensions

See figure 1 and table 1.

The shank diameter is approximately equal to the pitch diameter or equal to the major thread diameter permissible.

NOTE 1 Symbols and designations of dimensions are specified in ISO 225.

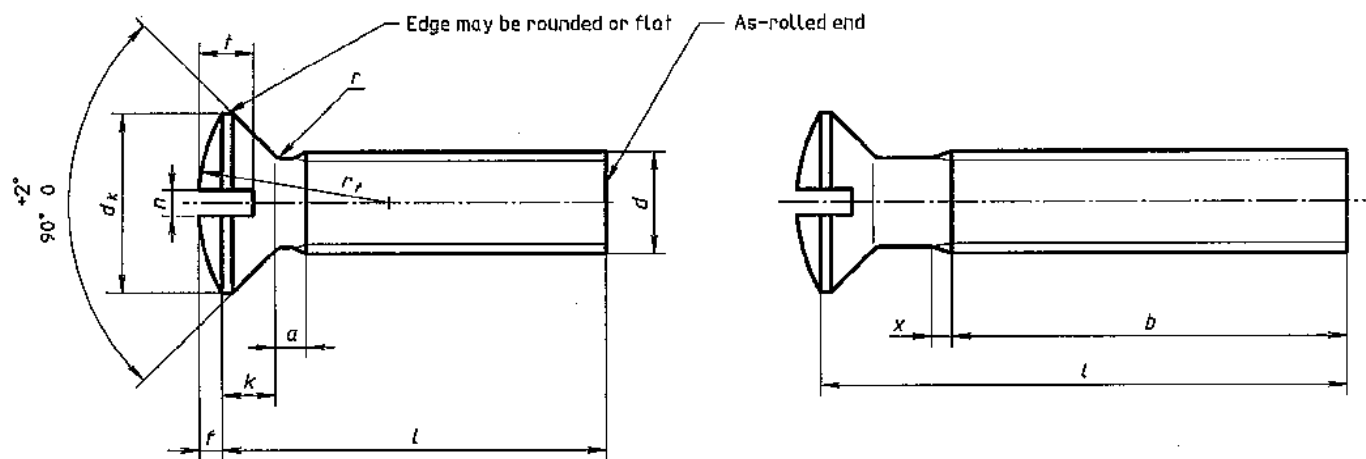

Figure 1



Table 1

Dimensions in millimetres

Thread (d)		M1,6	M2	M2,5	M3	(M3,5) ¹⁾	M4	M5	M6	M8	M10	
<i>P</i> ²⁾		0,35	0,4	0,45	0,5	0,6	0,7	0,8	1	1,25	1,5	
<i>a</i>	max.	0,7	0,8	0,9	1	1,2	1,4	1,6	2	2,5	3	
<i>b</i>	min.	25	25	25	25	38	38	38	38	38	38	
<i>d_k</i> ³⁾	theoretical	max.	3,6	4,4	5,5	6,3	8,2	9,4	10,4	12,6	17,3	20
	actual	nom. = max.	3,0	3,8	4,7	5,5	7,30	8,40	9,30	11,30	15,80	18,30
		min.	2,7	3,5	4,4	5,2	6,94	8,04	8,94	10,87	15,37	17,78
<i>f</i>	≈	0,4	0,5	0,6	0,7	0,8	1	1,2	1,4	2	2,3	
<i>k</i> ³⁾	nom. = max.	1	1,2	1,5	1,85	2,35	2,7	2,7	3,3	4,65	5	
<i>n</i>	nom.	0,4	0,5	0,6	0,8	1	1,2	1,2	1,6	2	2,5	
	max.	0,60	0,70	0,80	1,00	1,20	1,61	1,61	1,91	2,31	2,81	
	min.	0,46	0,56	0,66	0,86	1,06	1,26	1,26	1,66	2,06	2,56	
<i>r</i>	max.	0,4	0,5	0,6	0,8	0,9	1	1,3	1,5	2	2,5	
<i>r_f</i>	≈	3	4	5	6	8,5	9,5	9,5	12	16,5	19,5	
<i>t</i>	max.	0,80	1,0	1,2	1,45	1,7	1,9	2,4	2,8	3,7	4,4	
	min.	0,64	0,8	1,0	1,20	1,4	1,6	2,0	2,4	3,2	3,8	
<i>x</i>	max.	0,9	1	1,1	1,25	1,5	1,75	2	2,5	3,2	3,8	
nom.	^{1),4)} min.	max.	Approximate mass, in kilograms per 1 000 pieces ($\rho = 7,85 \text{ kg/dm}^3$) (for information only)									
2,5	2,3	2,7	0,062									
3	2,8	3,2	0,067	0,119								
4	3,76	4,24	0,078	0,138	0,242							
5	4,76	5,24	0,09	0,166	0,272	0,395						
6	5,76	6,24	0,102	0,175	0,302	0,439	0,729	1,07				
8	7,71	8,29	0,125	0,212	0,362	0,527	0,849	1,23	1,73	2,79		
10	9,71	10,29	0,145	0,249	0,422	0,615	0,969	1,39	1,97	3,14	6,89	
12	11,65	12,35	0,165	0,287	0,482	0,703	1,09	1,54	2,21	3,49	7,53	11,4
(14)	13,65	14,35	0,185	0,325	0,543	0,791	1,21	1,7	2,45	3,84	8,17	12,5
16	15,65	16,35	0,205	0,362	0,603	0,879	1,33	1,85	2,69	4,19	8,81	13,5
20	19,58	20,42		0,436	0,723	1,06	1,57	2,17	3,17	4,89	10,1	15,5
25	24,58	25,42			0,874	1,28	1,87	2,66	3,77	5,77	11,7	18
30	29,58	30,42				1,5	2,17	2,95	4,37	6,64	13,3	20,6
36	34,5	35,5					2,47	3,34	4,97	7,62	14,9	23,1
40	39,5	40,5						3,73	5,57	8,39	16,5	25,6
45	44,5	45,5							6,16	9,27	18,1	28,1
50	49,5	50,5							6,76	10,1	19,7	30,7
(55)	54,05	55,95								11	21,3	33,2
60	59,05	60,95								11,9	22,9	35,7
(65)	64,05	65,95									24,5	38,2
70	69,05	70,95									26,1	40,8
(75)	74,05	75,95									27,7	43,3
80	79,05	80,95									29,3	45,8

NOTE — Commercial lengths are shown between the stepped, continuous, bold lines.

- 1) Sizes in parentheses should be avoided if possible.
- 2) *P* = pitch of the thread
- 3) See ISO 7721.
- 4) Screws with nominal lengths above the bold dotted line are threaded up to the head; $b = l - (k + a)$.

4 Specifications and reference International Standards

See table 2.

Table 2

Material		Steel	Stainless steel	Non-ferrous metal
General requirements	International Standard	ISO 8992		
Thread	Tolerance	6g		
	International Standards	ISO 261, ISO 965-2		
Mechanical properties	Property class	4.8, 5.8	A2-50, A2-70	...
	International Standards	ISO 898-1	ISO 3506	ISO 8839
Tolerances	Product grade	A		
	International Standard	ISO 4759-1		
Finish		Plain Requirements for electroplating are covered in ISO 4042. If different electroplating requirements are desired or if requirements are needed for other finishes, they shall be agreed between customer and supplier. Limits for surface discontinuities are covered in ISO 6157-1.		
Acceptability		Acceptance procedure is covered in ISO 3269.		

5 Designation

Example of designation: A countersunk slotted raised head screw with thread M5, nominal length $l = 20$ mm and property class 4.8 is designated as follows:

Countersunk raised head screw ISO 2010 - M5 × 20 - 4.8



ICS 21.060.10

Descriptors: fasteners, screws, slotted head screws, raised head screws, countersunk head screws, specifications, dimensions, designation.

Price based on 4 pages
